

GRAPPLE SKIDDER

The **"E"** version of the **WORLD'S LARGEST SKIDDER** features:

- Cummins QSM11 Tier III engine providing 400 hp @ 2100 rpm
- New tropical hydraulic and engine cooling system
- Proven reliable and low maintenance hydrostatic drive system
- Extremely low ground pressure for minimum ground disturbance
- IQAN control system
- Excellent stability for safe steep slopes forwarding (Engine pan designed for 45% slope).
- Ergonomic cab design and electro-proportional joystick handles (No oil in the cab)
- Easy to service and built to last
- Wheel tandems mounted on ball bearings for easier service and lower operating cost
- Excellent boom geometry with a large 45 ft² grapple and a heavy duty rotator

**You can fell it?
We can SKID it!**

The TG88E can skid where ever you are able to mechanically fell with a feller buncher. Soft ground, deep snow or steep slopes; the TG88E is The Canadian all weather, all terrain, year round skidding solution!

**The Tanguay
Personalized Approach:**

TG products are designed from the ground up with high quality components for exceptional reliability and superior performance over the long term. We listen and provide customized fully engineered products to suit your logging business. A solid investment in any language!



Technical specifications

Grapple skidder

TG88E

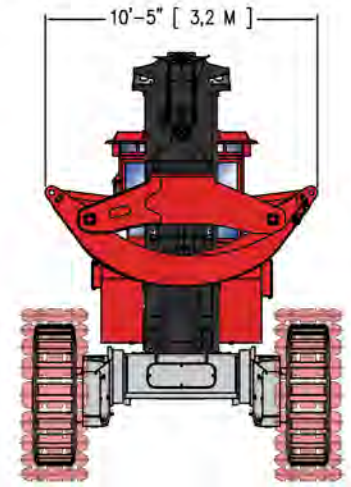
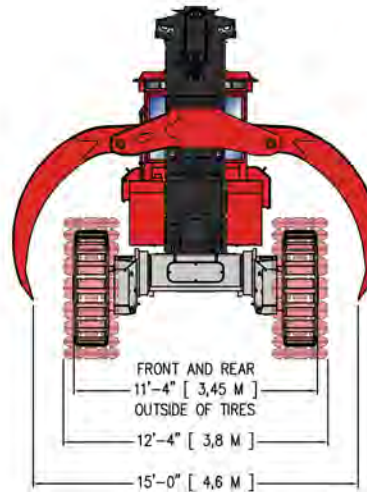
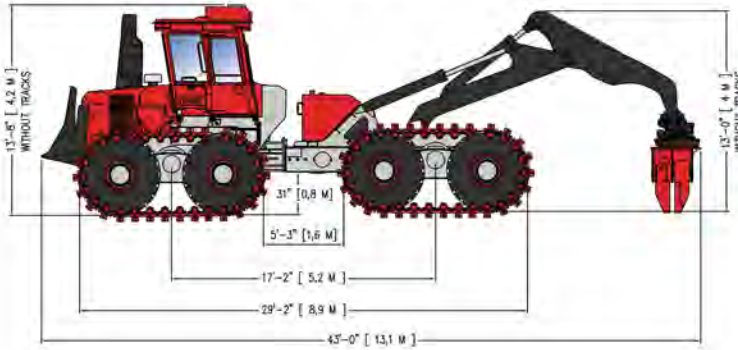

Engine:	Cummins QSM11 , Tier III, 400 hp (300 kw)@ 2100 rpm
Base machine weight:	84000 lbs (38 000 kg) without tracks
Cooling:	Engine: Large 36" suction fan in front of two sections side by side coolers (Charged air & coolant) Hydraulic: Dual hydraulically driven thermostatic variable speed and reversible 19" fan. Optional electrical auxiliary oil cooler for tropical conditions.
Booms & Accumulating Grapple:	Huge 45 ft(4.2 m2) grapple with dual booms providing 15 feet reach and a lift capacity of 23 000 lbs (10 400 kg) at full reach.
Fuel reservoir:	210 US gal (800 liters)
Draw Bar Pull:	148 000 lb (662 KN)
Maximum Driving Speed:	5 mph (8 km/h)
Traction:	Closed loop hydraulic with four 75 gpm (284 l/min) variable displacement drive pumps powering eight variable displacement drive motors mounted on a planetary gear reduction final drives. No need for high maintenance transmission, differential or drive lines.
Traction Control System:	In-board computer senses the steering angle of the machine and adjusts the flow of each of the four traction pumps for the required tandem speed to maximize driving speed and available horse power.
Hydraulic system:	IQAN control system and two 62 gpm (207 l/min) implement pumps for the grapple booms, steering and dozer blade functions. Two pressurized hydraulic tanks for a total capacity of 108 US Gal (410 litre) and one 13,2 US Gal (50 litres) refill tank. Full flow return line immersion filters with easy to replace cartridges. ORS fittings.
Brake:	Hydrostatic working brake and spring applied/pressure release parking brakes in each wheel planetary.
Tires:	Eight 18 x 25,32 ply tires with sprocket type TG grooves for positive track power transfer.
Tracks:	Standard or banana style tracks up to 60 inches (1,5 m) wide for low ground pressure
Electrical system:	One 24 V 100A alternator and (18) halogen lights.
Cold start-up :	Two 110V electrical engine heaters and two hydraulic tank heaters. Optional Espar heating system.
Cab :	Ergonomic and fully adjustable suspension seat with heavy duty swivel base and electro-proportional joysticks (No oil in the cab. Large 27000 BTU air conditioner and heater systems. Hydraulically tiltable cab for easy service access. Complete instrumentation panel. Design to meet ROPS, FOPS and OPS Regulations.
Additional options :	Fire suppression system, Automatic greasing system, Auxiliary cooler for tropical conditions, Ice breaking wheel chains
	Note: Specifications subject to change without notice.



www.tanguay.cc